

Mechanical Phase Shifters



- /// DC to 20 GHz; Low Loss; Linear
- /// **Self Locking** - Internal mechanism eliminates the need for a locking nut. Ideal for phase trimming in densely packaged systems with minimum accessibility.
- /// **EDGE LINE** designs for ultra fine resolution to 22 GHz
- /// **COAXIAL** designs for broadband low-loss operation to 18 GHz
- /// **STRIPLINE** designs for lower cost applications to 12 GHz

General Information





In this section of the catalog, each Phase Shifter is outlined utilizing individual data sheets containing product features, specifications, and outline drawings. These data sheets are preceded by a quick reference guide to help you select the Phase Shifter(s) that fits your needs. The page number for each phase shifter data sheet is given in the quick reference guide.

Aeroflex / Weinschel offers a variety of Mechanical Phase Shifter designs that are ideally suited for delay line applications in optical and RF Networks. These designs provide linear adjustable phase shift in a very small in-line coaxial packages with long mechanical cycle life. Models can also be easily adapted to motorized control configurations.

NOTE: **EXPRESS** Shipment available via www.argosysales.com or 800-542-4457. Check with distributor for current products and stocking quantities.



Phase Shifters...dc to 20 GHz

Model Number	Frequency Range (GHz)	Connector Type	Incremental Phase Shift (Minimum)	Insertion Phase (Typical)	Average Power (Watts)	Maximum Insertion Loss (dB)	Maximum SWR	Page No.	
★ 917	dc to 20.0	2.92mm	225° @ 20 GHz, 100° at 9 GHz.	890° @ 10 GHz	200	0.8	1.50	200	
980-1	dc to 3.0	SMA	140° @ 3.0 GHz	560° @ 3.0 GHz	10	0.7-1.2*	1.30	199	
★ 980-2	dc to 3.0	SMA	165° @ 1.5 GHz 330° @ 3.0 GHz	780° @ 3.0 GHz	10	1.5-2.0*	1.35		
★ 980-3	dc to 7.0	SMA	85° @ 3.0 GHz 170° @ 7.0 GHz	700° @ 3.0 GHz	10	0.5	1.30		
★ 980-4	dc to 12.4	SMA	290° @ 12.0 GHz	1200° @ 12.0 GHz	10	1.0	1.45		
980K-1	dc to 3.0	SMA	140° @ 3.0 GHz	560° @ 3.0 GHz	10	0.7-1.2*	1.30	199	
★ 980K-2	dc to 3.0	SMA	165° @ 1.5 GHz 330° @ 3.0 GHz	780° @ 3.0 GHz	10	1.5-2.0*	1.35		
980K-3	dc to 7.0	SMA	85° @ 3.0 GHz 170° @ 7.0 GHz	700° @ 3.0 GHz	10	0.5	1.30		
980K-4	dc to 12.4	SMA	290° @ 12.0 GHz	1200° @ 12.0 GHz	10	1.0	1.45		
★ 981	dc to 18.0	3.5mm	60° /GHz	---	50	0.5+0.35 f * f = GHz	1.80	202	

* VARIES WITH FREQUENCY.

★ EXPRESS Shipment available via www.argosysales.com or 800-542-4457.

Note: Other models may also be available from Express delivery.

Mechanical Phase Shifters



Model 980 Coaxial Phase Shifters

dc to 3.0/7.0/12.0 GHz
10 Watts

Ruggedized SMA Connector

RoHS

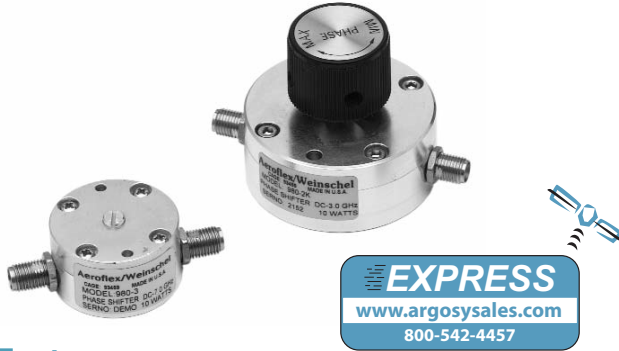

Features

- /// **Self Locking** - Internal mechanism eliminates the need for a locking nut. Ideal for phase trimming in densely packaged systems with minimum accessibility.
- /// **Available Express Models** - 980-2, 980-2K, 980-3, 980-4
Other models may be available for Express Delivery.
- /// **Linear** - Nominally linear phase over the frequency range.
- /// **Optimized for Wireless OEM Applications.**
- /// **New Models with Adjustment Knobs**
(See Models 980-1K through 980-4K).

Specifications

NOMINAL IMPEDANCE: 50 Ω

FREQUENCY RANGE:

Model 980-1 & 980-1K: dc to 3.0 GHz
 Model 980-2 & 980-2K: dc to 3.0 GHz
 Model 980-3 & 980-3K: dc to 7.0 GHz
 Model 980-4 & 980-4K: dc to 12.0 GHz

INCREMENTAL PHASE SHIFT:

Model 980-1 & 980-1K: 140° minimum @ 3.0 GHz
 Model 980-2 & 980-2K: 165° minimum @ 1.5 GHz
 330° minimum @ 3.0 GHz
 Model 980-3 & 980-3K: 85° minimum @ 3.5 GHz
 170° minimum @ 7.0 GHz
 Model 980-4 & 980-4K: 290° minimum @ 12.0 GHz

MAXIMUM INSERTION LOSS (dB):

Model No.	Frequency Range (GHz)			
	1.5	3.0	7.0	12.0
980-1 & -1K	0.70 dB	1.20 dB	---	---
980-2 & -2K	1.50 dB	2.00 dB	---	---
980-3 & -3K	0.50 dB	0.50 dB	0.50 dB	---
980-4 & -4K	1.00 dB	1.00 dB	1.00 dB	1.00 dB

INSERTION PHASE:

Model 980-1 & 980-1K: 560° (Typical) @ 3.0 GHz
 Model 980-2 & 980-2K: 780° (Typical) @ 3.0 GHz
 Model 980-3 & 980-3K: 700° (Typical) @ 7.0 GHz
 Model 980-4 & 980-4K: 1200° (Typical) @ 12.0 GHz

PHASE VS FREQUENCY: Nominally linear response

MAXIMUM SWR:

Frequency Range (GHz)	Model No.			
	908-1/1K	980-2/2K	980-3/3K	980-4/4K
dc - 3	1.30	1.35	1.30	1.30
3 - 7	---	---	1.30	1.30
7 -12	---	---	---	1.60

POWER RATING: 10 watts average

TEMPERATURE RANGE:

Operating: -50°C to 85°C
 Storage: -50°C to 125°C

CONNECTOR: SMA female connector per MIL-STD-348 interface dimensions - mate nondestructively with MIL-C-39012 connector.

WEIGHT: Models 980-1 & 980-2: 50 g (1.80 oz)
 Models 980-1K & 980-2K: 60 g (2.14 oz)
 Model 980-3 & 980-4: 25 g (0.88 oz)
 Model 980-3K & 980-4K: 35 g (1.24 oz)

PHYSICAL DIMENSIONS:

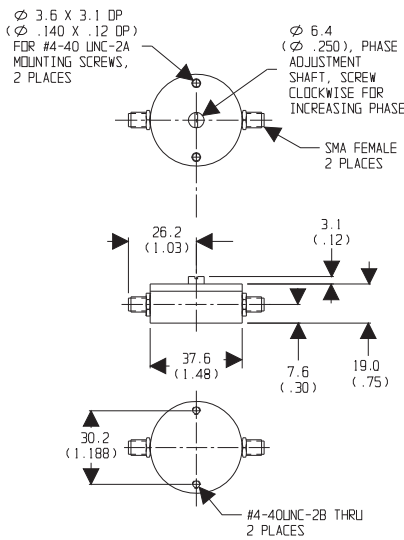

MODEL 980-1

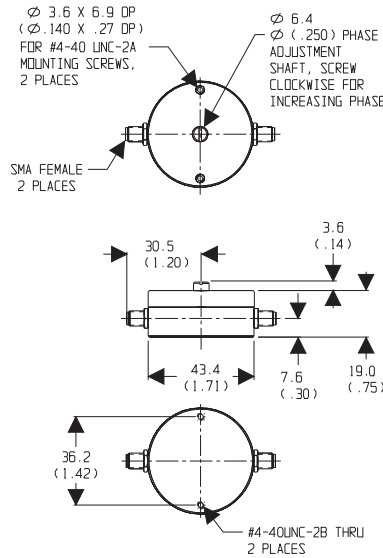

MODEL 980-2

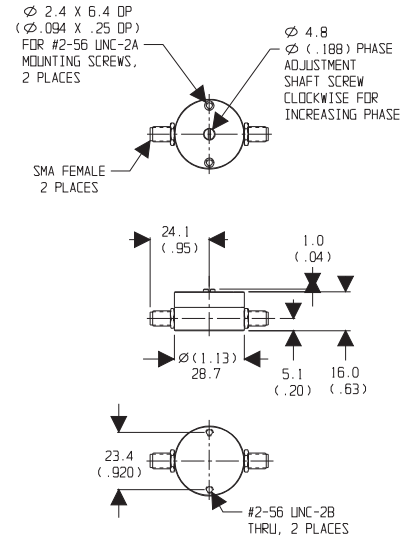

MODELS 980-3 & 980-4

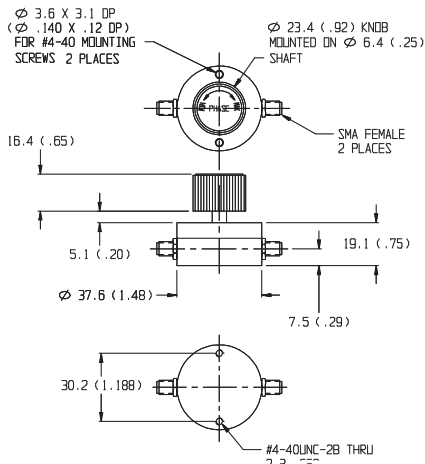

MODEL 980-1K

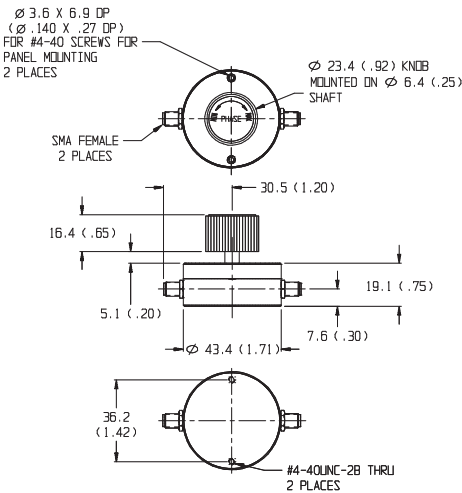

MODEL 980-2K

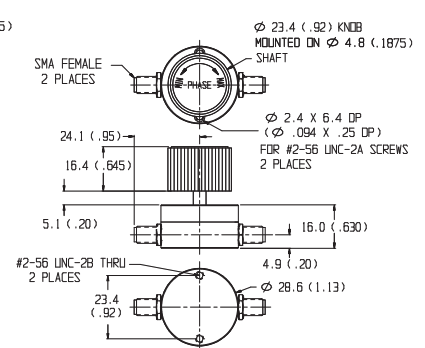

MODEL 980-3K & 980-4K

NOTE:

1. All dimensions are given in mm (inches) and are maximum, unless otherwise specified.
2. Unit available with RoHS compliant materials, specify when ordering.

Mechanical Phase Shifters



Model 917 Miniature In-Line Phase Shifter

dc to 20.0 GHz
200 Watts

Ruggedized 2.92mm Connector



Features

- /// **Self Locking** - Internal mechanism eliminates the need for a locking nut. Ideal for phase trimming in densely packaged systems with minimum accessibility.
- /// **Linear** - Provides a linear adjustable phase shift to 20 GHz in a very small in-line coaxial package.

Specifications

- NOMINAL IMPEDANCE:** 50 Ω
- FREQUENCY RANGE:** dc to 20.0 GHz
- INCREMENTAL PHASE SHIFT:** Adjustable to 225° @ 20 GHz; 100° at 9 GHz.
- RESOLUTION:** 0.5° per turn per GHz, typical (Adjustment shaft has 20 turns for full range).
- INSERTION PHASE:** 890° @ 10 GHz (Typical)
- PHASE VS FREQUENCY:** Nominally linear response
- INSERTION LOSS:** 0.8 dB maximum (0.5 dB typical @ 20 GHz)

MAXIMUM SWR:	
Frequency Range (GHz)	SWR
dc - 20	1.5

POWER RATING: 200 watts average
TEMPERATURE RANGE: -55°C to 125°C.

CONNECTOR: 2.92mm connector compatible with SMA, 3.5mm, SMK and other 2.92mm connectors. Available connector options are:

Connector Options	Type/Description
1	2.92mm, Female
2	2.92mm, Male

WEIGHT: 45 g (1.6 oz)

PHYSICAL DIMENSIONS:

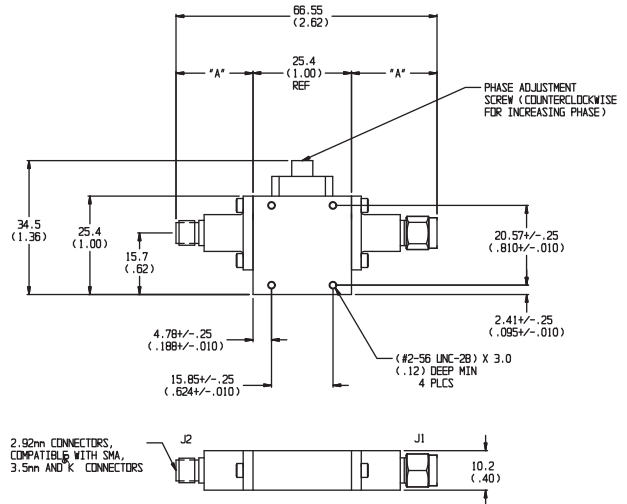

CONN TYPE	DIM A
Female	19.81 (0.78)
Male	21.34 (0.84)

NOTE: All dimensions are given in mm (inches) and are nominal ± 0.5 (0.02), unless otherwise specified.

MODEL NUMBER DESCRIPTION:

Example:

917 - XX

Basic Model Number

Connector Options*
1st digit is J1 side
2nd digit is J2 side

Model 981 Coaxial Phase Shifter

dc to 18.0 GHz
50 Watts

3.5mm Connectors

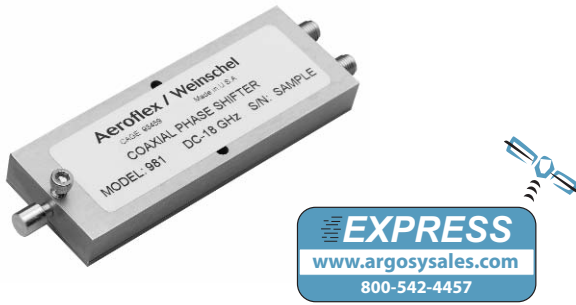

Features

- /// **Broadband Frequency Coverage:** Operates from dc to 18 GHz, usable to 20 GHz
- /// **Ideally suited for delay line applications in optical and RF Networks.**
- /// **Easily adapts to motorized control configurations.**
- /// **Designed for long mechanical cycle life.**

Specifications

NOMINAL IMPEDANCE: 50 Ω
FREQUENCY RANGE: dc to 18.0 GHz
INCREMENTAL PHASE SHIFT (Minimum): 60° /GHz
INSERTION LOSS (dB): 0.5 + 0.035 f(GHz)

MAXIMUM SWR:

Frequency Range (GHz)	SWR
dc - 10	1.6
10 - 18	1.8

POWER RATING: 50 watts average, 1 kW peak
TEMPERATURE RANGE: -50°C to 100°C.
CONNECTOR: 3.5mm female connectors compatible with 3.5mm, SMA, SMK and other 2.92mm connectors.
WEIGHT: 80 g (2.84 oz)

PHYSICAL DIMENSIONS:

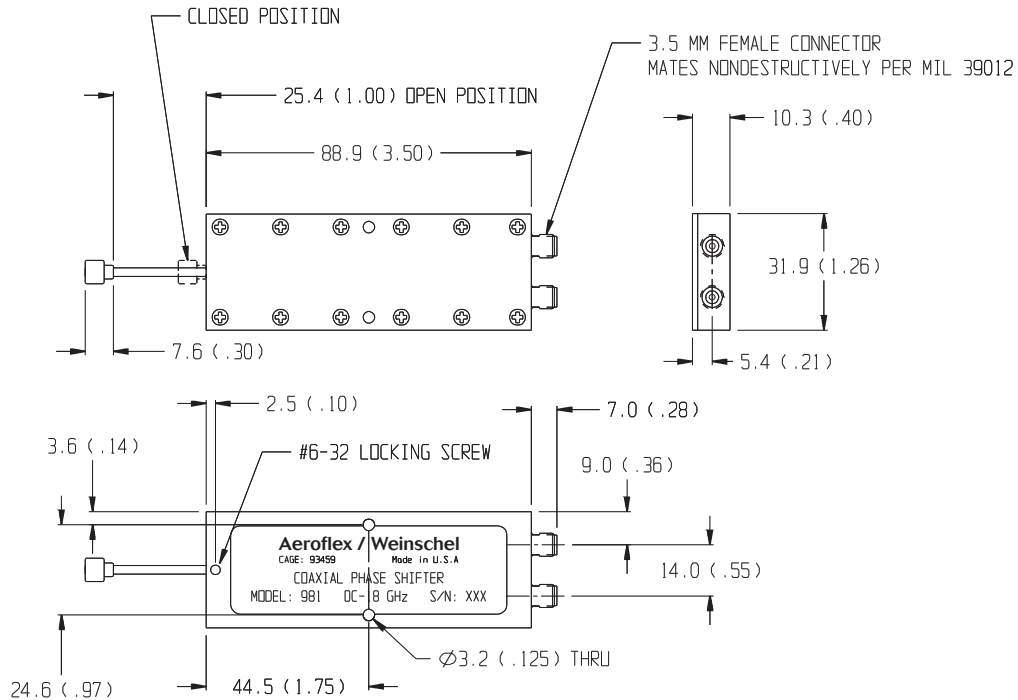

NOTE: All dimensions are given in mm (inches) and are maximum unless otherwise specified.