

XFT Series

Clamp-On Ultrasonic Flow Meter

The XFT uses an external clamp-on installation method, which eliminates the need for additional pipe cutting or fitting reducer unions. This allows for quick installation and significantly reduces the mechanical design and installation complexity of the fluid system.

Once installed, it requires no additional maintenance for long-term use. The measurement accuracy remains unaffected over extended periods.

Applications

- General automation machine cooling system
- Industrial chiller flow monitoring
- Liquid-cooled servers, CDU
- Semi-conductor process equipment
- Microwave/RF power supply cooling water monitor

Specifications

MEASUREMENT				
	PIPE SIZE	DIAMETER RANGE (OD)	GALLONS PER MINUTE	LITERS PER MINUTE
MAXIMUM FLOW RATE¹	3/8"	16 to 18 mm	7.9 GPM	30 LPM
	1/2"	18 to 23 mm	15.9 GPM	60 LPM
	3/4"	23 to 28 mm	26.4 GPM	100 LPM
	1"	28 to 37 mm	52.8 GPM	200 LPM
	1.25"	37 to 44 mm	79.3 GPM	300 LPM
	1.5"	44 to 52 mm	105.7 GPM	400 LPM
SUPPORT FLUID MEDIA	Compatible with Various Cooling Liquids, DI Water, Oil Substances, etc.			
SUPPORT PIPE	Stainless Steel, PVC, PPR (For other hard pipe materials, please consult the factory)			
FLOW ACCURACY²	Typical ±2% FS, Max ±3% FS			
FLUID TEMPERATURE RANGE	0° C to +60° C (+32° F to +140° F)			
TEMPERATURE ACCURACY	±2° C (Pipe Wall)			



Features

- Clamp-on design, no need for pipe cutting or fitting conversion, no moving parts, no pressure loss, no contaminations
- Elegant true-color LCD interface with rotatable orientation
- Supports 16 to 52mm (3/8" to 1.5") pipe out diameters, compatible with stainless steel, PVC, PPR, and other similar materials
- Additional MODBUS® RTU communication interface and analog temperature measurement
- CE/REACH Certified

ELECTRICAL	
SUPPLY VOLTAGE	12 to 30 VDC with Reverse Polarity Protection
OUTPUT	4-20 mA RS485 with Short-Circuit Protection
CONNECTION	M-12 A-Code 8-Pin Male
DAMPING TIME	0.5, 1, 5 (Default), 10 seconds

ENVIRONMENT	
AMBIENT TEMPERATURE	-10° C to +60° C (+14° F to +140° F)
IP RATING	IP66

¹Device features factory factory-configured low low-flow cutoff with adjustable threshold. When deactivated, detectable flow rates extend down to <1% Qmax.

²Calibration is performed at room temperature using internal equipment with clean water at ambient temperature, in accordance with the selected tubing material specifications. , lowest calibrated flow rate listed as below:

- 3/8" to 3/4" (16 to 28 mm): Minimum calibration point at 10% Qmax
- 1" to 1-1/4" (28 to 44 mm): Minimum calibration point at 7.5% Qmax
- 1-1/2" (44 to 52 mm): Minimum calibration point at 10% Qmax

³The verified wall thickness during the development phase meets or exceeds the following values. In practice, wall thicknesses at or below this threshold are suitable for standard measurements. For applications requiring greater wall thickness, it is advisable to confirm suitability by evaluating actual samples through testing.

Nominal Diameter	Materials		
	Stainless Steel	PPR	PVC
DN10	3.0 mm	3.0 mm	2.0 mm
DN15 / DN20	3.0 mm	3.0 mm	2.0 mm
DN25 / DN32	4.0 mm	4.0 mm	2.0 mm
DN40	5.0 mm	5.0 mm	2.5 mm

CERTIFICATE	
CERTIFICATES	CE / REACH / RoHS

FUNCTION	
ANALOG	Flow Rate, Temperature
DISPLAY	Flow Rate, Temperature, Cumulative Flow, Signal Strength, Output Percentage
MODBUS RTU	Flow Rate, Temperature, Cumulative Flow, Reset Cumulative Flow, Signal Strength, Access to all Parameters

PARAMETER ADJUSTMENT	
	Automatic Optimization
	Advance Calibration
	Flow/Temperature Output Ratio Adjustment
	Pipe Outer Diameter
	Pipe Wall Thickness
	Pipe Material
	Sound Velocity
	Damping Coefficient
	Flow Compensation Coefficient
	Password Protection
	Modbus Baud Rate and Address

Dimensions

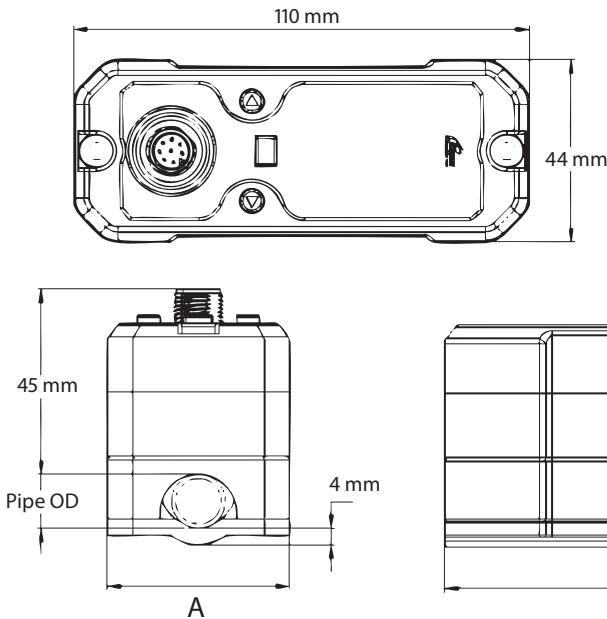

PIPE SIZE	DIAMETER (OD)	A
3/8"	16 to 18 mm	44 mm (1.73")
1/2" to 3/4"	18 to 28 mm	50 mm (1.97")
1" to 1-1/4"	28 to 44 mm	69 mm (2.72")
1-1/2"	44 to 52 mm	89 mm (3.5")

MODBUS® is a registered trademark of Schneider Electric USA, Inc. in Palatine, IL.

Configuration

XFT	D	X	A	L	0	00	
SERIES	OUTPUT	OD ¹ mm (OD) DN INCHES	PIPE ²	FLUID TEMPERATURE	TEMPERATURE		
D	4-20 mA & Modbus	D 16 - 18 E 18 - 23 F 23 - 28 G 28 - 37 H 37 - 44 J 44 - 52	DN10 DN15 DN20 DN25 DN32 DN40	3/8" 1/2" 3/4" 1" 1-1/4" 1-1/2"	A SS B PPR C PVC	L +60° C	1 Yes

Please contact GEMS Engineers prior to measuring other pipe materials.

¹Actual model selection must strictly follow the outer diameter in millimeters. In case of a borderline measurement. For example, 18mm should correspond to Model E.

²To ensure measurement accuracy, the product is calibrated based on the selected pipe material before leaving the factory. After receiving the product, the pipe material can be modified, but this may affect measurement accuracy.

Wiring

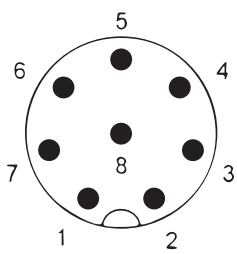

PIN / COLOR	CONNECTION
1 / White	T-Out
2 / Brown	Modbus A+
3 / Green	Modbus B-
4 / Yellow	GND
5 / Gray	VCC+
6 / Pink	N/A
7 / Blue	F-Out (Flow Rate)
8 / Red	N/A